

**RibLoc® U Plus CHEST WALL PLATING SYSTEM**  
**FOR THE PERSONAL ATTENTION OF THE OPERATING SURGEON**

**INSTRUCTIONS FOR USE**

<b>DESCRIPTION</b>	The RibLoc® U Plus Chest Wall Plating System of bone plates, screws and accessories are designed to provide fixation for fractures, fusions, and osteotomies of the ribs, and reconstructions of the chest wall.
<b>INFORMATION FOR USE</b>	Anatomical dimensions determine the size and shape of implant used. The surgeon must select the appropriate size, and contour the plate if necessary, to match the patient's anatomy for close adaptation and firm seating with adequate support.
<b>INDICATIONS</b>	The RibLoc® U Plus Chest Wall Plating System is intended to stabilize and provide fixation for fractures, fusions, and osteotomies of the ribs, and for reconstructions of the chest wall, and sternum.
<b>CONTRAINDICATIONS</b>	<ul style="list-style-type: none"> <li>• Contraindications for this system are active or latent infection, sepsis, insufficient quantity or quality of bone/soft tissue, and material sensitivity. If metal sensitivity is suspected, tests should be performed prior to implantation.</li> <li>• Patients who are unwilling or incapable of following postoperative care instructions are contraindicated for this device.</li> <li>• This device is not intended for screw attachment or fixation to the posterior elements (pedicles) of the cervical or lumbar spine.</li> </ul>
<b>WARNINGS</b>	<ul style="list-style-type: none"> <li>• For safe and effective use of this implant, the surgeon must be thoroughly familiar with the implant, the methods of application, the instruments, and the recommended surgical technique for this device.</li> <li>• Surgeons must carefully consider the likelihood of healing being achieved when plating fractures, osteotomies, or reconstructions of the chest wall. This system is only designed to withstand loading during a reasonable healing time period and is not intended to be a permanent prosthesis.</li> <li>• Surgeons must consider a possible need for emergent reentry, such as sternotomy, before plating the sternum.</li> <li>• Improper insertion of the device during implantation can increase the possibility of loosening or migration.</li> <li>• A poorly contoured plate may result in an abnormal load on bones or may result in patient discomfort.</li> <li>• Device damage or breakage can occur when the implant is subjected to increased loading associated with trauma, delayed union, nonunion or incomplete healing. Device breakage could lead to additional surgery and device removal.</li> <li>• The patient must be cautioned, preferably in writing, about the use, limitations, and possible adverse effects of this implant. These cautions include the possibility of the device or treatment failing as a result of loose fixation and/or loosening, stress, excessive activity, or continuous load bearing past the average healing time (6-8 weeks), particularly if the implant experiences increased loads due to delayed union, nonunion, or incomplete bone healing.</li> <li>• The patient must be warned that failure to follow postoperative care instructions can cause the implant and/or treatment to fail.</li> <li>• As with any surgical implantation there is a possibility of nerve, bone or soft tissue damage related to either surgical trauma or the presence of the implant.</li> <li>• The implant system has not been evaluated for use in pectus deformity repair, or costochondral junction fracture.</li> </ul>

<p><b>MRI Safety Information</b></p>  <p><b>MR Conditional</b></p>	<p>Non-clinical testing and MRI simulations were performed to evaluate the RibLoc® Plating System. Non-clinical testing demonstrated that the entire family of this product is MR Conditional. A patient with an implant from this product family can be scanned safely in an MR system under the following conditions:</p> <ul style="list-style-type: none"> <li>• Static magnetic field of 1.5-Tesla or 3-Tesla, only</li> <li>• Maximum spatial gradient magnetic field of 4,000-gauss/cm (40-T/m)</li> <li>• Maximum MR system reported, whole body averaged specific absorption rate (SAR) of 2-W/kg for 15 minutes of scanning (i.e., per pulse sequence) in the Normal Operating Mode</li> </ul> <p>Under the scan conditions defined, an implant from RibLoc® Plating System is expected to produce a maximum temperature rise of 8.1°C after 15-minutes of continuous scanning (i.e., per pulse sequence).</p> <p>In non-clinical testing, the image artifact caused by and implant from RibLoc® Plating System extends approximately 10-mm from this device when imaged with a gradient echo pulse sequence and a 3-Tesla MR system.</p>
<p><b>PRECAUTIONS</b></p>	<ul style="list-style-type: none"> <li>• An implant shall never be reused. Previous stresses may have created imperfections which can lead to a device failure.</li> <li>• Extreme or repeated bending of the implants can cause stresses that may lead to premature device failure.</li> <li>• Ensure that RibLoc® plates and U-clips are not damaged prior to installation, and use care when handling to prevent U-clip deformation.</li> <li>• Over-compression of the U-Clip during implant installation can damage the bone.</li> <li>• Instruments should be inspected for wear or damage prior to usage.</li> <li>• The drill bit shall be discarded after each surgery since after normal use the drill bit can become too dull to perform as intended.</li> <li>• If a plate cutter is used on the implant take necessary precautions, a sharp edge may have been created.</li> <li>• During use of a drill, cutting or installing plates and inserting screws, take necessary precautions when in close proximity to sharp edges and points, and be aware that metal debris/fragments can be generated. Remove any observed debris/fragments from the surgical field with suction or manually, and dispose of appropriately.</li> <li>• Protect implants against scratching and nicking prior to and during use. Prevent hexalobe drivers, drill bits and instruments to come into inadvertent contact with plates as such stress concentrations can lead to device failure.</li> <li>• The benefits from implant surgery may not meet the patient's expectations or may deteriorate with time necessitating revision surgery to replace the implant or to carry out alternative procedures. Revision surgeries with implants are not uncommon.</li> </ul>
<p><b>ADVERSE EFFECTS</b></p>	<ul style="list-style-type: none"> <li>• Possible adverse effects include pain, discomfort, or abnormal sensations due to the presence of an implant.</li> <li>• Implant fracture, migration and/or loosening may occur due to excessive activity, prolonged loading upon the device, incomplete healing, or excessive force exerted on the implant during insertion. These types of adverse effects could lead to additional surgery and device removal.</li> <li>• Nerve or soft tissue damage, necrosis of bone or bone resorption, necrosis of the tissue or inadequate healing may result from the presence of an implant or due to surgical trauma.</li> <li>• A histological or allergic reaction resulting from the implantation of a foreign material in the body may occur.</li> <li>• The implant contains metal that may induce an allergic reaction in patients with an allergy or sensitivity to metallic components.</li> </ul>

**CAUTION: Federal Law (USA) restricts this product sale by or on the order of a physician or hospital.**

**CLEANING AND STERILIZATION INSTRUCTIONS**

<p><b>PRECAUTIONS</b></p>	<ul style="list-style-type: none"> <li>• The RibLoc® U Plus Chest Wall Plating System products are provided non-sterile and require cleaning and sterilization prior to use.</li> <li>• Any device contaminated with blood, tissue or other bodily fluids should be handled according to hospital protocol. Personal protective equipment should be utilized when working with contaminated or potentially contaminated devices.</li> <li>• In accordance with AORN and AAMI guidelines, immediate use steam sterilization (also known as flash sterilization) of implants is not recommended.</li> <li>• Lumens, channels, crevices, joints, mating surfaces and threads require particular attention during cleaning. Flood with copious amounts of cleaning solutions using a syringe to flush out soil.</li> <li>• Caution should be exercised when handling instruments with sharp points or cutting edges.</li> <li>• Do not use metal brushes or scouring pads during manual cleaning process.</li> <li>• The use of neutral pH enzymatic and cleaning agents is recommended. If alkaline cleaning agents are used, neutralize and thoroughly rinse from device.</li> </ul>
<p><b>LIMITATIONS ON REPROCESSING</b></p>	<ul style="list-style-type: none"> <li>• Instruments are designed to withstand harsh cleaning and typical steam sterilization cycles.</li> <li>• Instrument end of life is normally determined by damage and wear due to use. Instruments and implants should be inspected after cleaning for damage such as corrosion, scratches and wear.</li> <li>• Damaged instruments should be returned to Acumed for replacement.</li> </ul>
<p><b>POINT OF USE:</b></p>	<ul style="list-style-type: none"> <li>• Remove biological material from the instruments with a lint-free disposable wipe.</li> <li>• Do not allow contamination to dry on the device prior to cleaning/reprocessing.</li> <li>• It is recommended that instruments are decontaminated as soon as possible following use.</li> </ul>
<p><b>PREPARATION FOR DECONTAMINATION:</b></p>	<ul style="list-style-type: none"> <li>• Disassembly of devices is not required.</li> <li>• Rinse instruments in warm (not hot) running water to remove blood, body fluids and remaining tissue. Transport devices (instruments and implants) in the tray provided.</li> </ul>
<p><b>CLEANING: MANUAL</b></p>	<p><u>Equipment:</u> Nylon soft bristle scrub brush (M16), pipe cleaner (2.7mm), lint-free cloth, irrigation syringe, warm running tap water and reverse osmosis or deionized (RO/DI) water, bath ultrasonic cleaner.</p> <p><u>Solutions:</u> Neutral pH (&lt;8.5) low foaming enzymatic detergent solution (e.g., Enzol®).</p> <ol style="list-style-type: none"> <li>1. Rinse soil from devices with warm running tap water.</li> <li>2. Prepare enzymatic detergents solution at the dilution recommended by the manufacturer in warm tap water. Fresh solutions should be prepared when existing solutions become contaminated.</li> <li>3. Submerge the devices in enzymatic solution and soak for a minimum of 3 minutes but no more than 5 minutes.</li> <li>4. Scrub with a soft bristle brush to remove all visible soil from the surfaces, crevices and channels. Rotate the devices while scrubbing paying particular attention to lumens, crevices, channels and hard to reach areas. Ensure that hinged, articulating and threaded instruments are cleaned in both open and closed positions.</li> <li>5. Remove the devices from the enzymatic solution and place in RO/DI water in an ultrasonic unit and sonicate for five (5) minutes.</li> <li>6. Rinse each device with ambient tap water and holding devices under water for 30 seconds to ensure lumens, crevices and channels are flushed with water. Use an irrigation syringe to flush water into lumens, crevices and mating surfaces.</li> </ol>
<p><b>DRYING</b></p>	<ul style="list-style-type: none"> <li>• Remove devices from water and wipe devices dry with a clean, lint-free cloth then allow to air dry.</li> </ul> <p>Load devices into the provided tray according to the diagram on the tray bottom. For automated processing, transfer the trays to the washer/disinfector.</p> <p><b>NOTE: Surgical instruments made from stainless steel can corrode and must be dried to prevent rust formation.</b></p>

**CAUTION: Federal Law (USA) restricts this product sale by or on the order of a physician or hospital.**

<b>CLEANING: AUTOMATED</b>	<p><u>Equipment:</u> An automated washer-disinfector that has been installed and qualified to ISO 15883-1 and ISO 15883-2.</p> <p><u>Solutions:</u> Prepare solutions per manufacturer's instructions. Use Neutral pH (&lt;8.5) low foaming, enzymatic wash solution (e.g., Enzo<sup>®</sup>), neutral pH, low foaming wash solution (e.g., Prolystica Neutral 2x), instrument lubricant (e.g., Ultra Clean Surgical Milk) if capable.</p> <p><b>NOTE:</b> Explicitly follow washer/disinfector manufacturer's instructions for loading.</p> <p><b>Motor Speed:</b> High</p>			
	<p><b>Phase</b></p>	<p><b>Recirculation Time</b></p>	<p><b>Temperature</b></p>	<p><b>Detergent Type and Concentration</b> *or equivalent</p>
	<p>Pre-wash</p>	<p>2:00 minutes</p>	<p>Cold tap water</p>	<p>N/A</p>
	<p>Enzyme Wash</p>	<p>4:00 minutes</p>	<p>Hot tap water</p>	<p>*Enzo<sup>®</sup> 1 oz/gal</p>
	<p>Wash</p>	<p>2:00 minutes</p>	<p>65.5°C (150°F)</p>	<p>*Prolystica 2x Neutral 1/8 oz/gal</p>
	<p>Rinse</p>	<p>15 seconds</p>	<p>Hot tap water</p>	<p>N/A</p>
	<p>Drying</p>	<p>6:00 minutes</p>	<p>98.8°C (210°F)</p>	<p>N/A</p>
<b>MAINTENANCE, INSPECTION, AND TESTING:</b>	<ul style="list-style-type: none"> <li>• Inspect device under normal lighting to ensure soil has been removed. If any visible soil is seen, repeat cleaning process.</li> <li>• Some automated washer/disinfectors have a cycle that includes a lubricant. If a washer/disinfector includes a lubricant, manual application of a lubricant is not necessary.</li> <li>• Inspect the clean and dried devices for wear or damage prior to sterilization. If any damage or corrosion is observed, contact Acumed for a replacement.</li> </ul>			

OBSOLETE  
Visit [www.acumed.com](http://www.acumed.com) for the latest version.

Three instruments in the RibLoc U Plus System have articulating parts that require lubrication after every cleaning, and prior to autoclaving. Only water soluble, non-silicone, steam permeable lubricants intended for surgical instruments (e.g., Ultra Clean Spray Lube or Surgical Milk) should be used. When applicable, consult your sterilization equipment manufacturer's written instructions regarding instrument lubrication for the specific sterilizer used. Fully submerging the instruments in lubricant is never advised.

Manually spray a small amount of lubricant onto the instruments at articulation areas, where mated surfaces make contact, on exposed screw threads and at hinges (see Figures 1-3). Actuate devices to ensure lubricant is distributed over the surfaces. Allow lubricated instruments to air dry prior to sterilization.

If the instruments are difficult to actuate, threads bind or components do not move smoothly over mating surfaces, contact Acumed for a replacement.

**Figure 1 – Plate Bender Lubricant Application Areas**  
a. Pivoting joint, b. Rollers

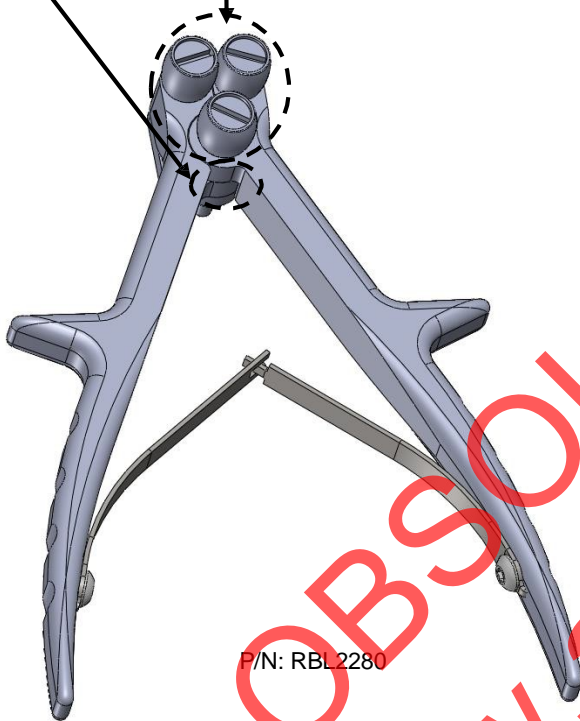

**Figure 2 – Intermediate Gauge Lubricant Application Areas**  
a. Threaded slider, b. Bearing surfaces



**Figure 3 – Primary Guide Lubricant Application Areas**  
a. Mating surfaces, b. Screw threads

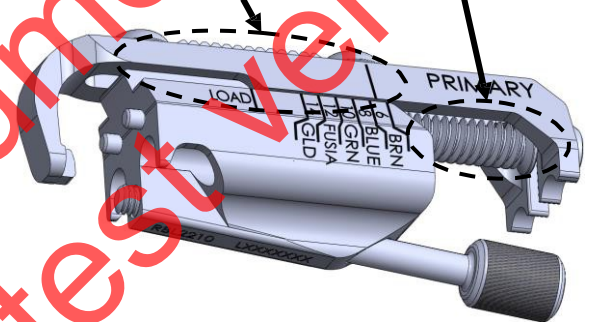

**PACKAGING:**



- The implants and instruments should be placed into appropriate locations in the accompanying surgical tray.
- Wrap the tray in two layers of 1 ply polypropylene wrap (e.g., Kimguard KC600) and place in a steam sterilizer.

**STERILIZATION:**











- This product is provided non-sterile. The steam sterilization method identified below has been validated to the requirements of ISO 17665. Please consider your sterilization equipment manufacturer's written instructions for the specific sterilizer and load configuration used.

System Tray Part Number	System Tray Approximate Dimensions	Pre-Vacuum Autoclave		
		Temperature	Cycle Time	Dry Time
RBL4020	26 x 54 x 8 cm (10 x 21 x 5 inch)	132°C (270°F)	4 min	30 min
		135°C (275°F)	3 min	25 min

**CAUTION: Federal Law (USA) restricts this product sale by or on the order of a physician or hospital.**

<b>STORAGE:</b>	Following drying, allow the surgical tray to cool before touching with unprotected hands. Remove surgical tray from the autoclave and store at ambient temperature and humidity, keep away from direct sunlight. Prior to use, inspect tray and contents for wear, damage or tampering.	
<b>MANUFACTURER CONTACT:</b>	  Acumed Headquarters 5885 NE Cornelius Pass Road Hillsboro, OR 97124 USA Office: +1.888.627.9957 Office: +1.503.627.9957 Fax: +1.503.520.9618	These materials contain information about products that may or may not be available in any particular country or may be available under different trademarks in different countries. The products may be approved or cleared by governmental regulatory organizations for sale or use with different indications or restrictions in different countries. Products may not be approved for use in all countries. Nothing contained in these materials should be construed as a promotion or solicitation for any product or for the use of any product in a particular way that is not authorized under the laws and regulations of the country where the reader is located. Nothing in these materials should be construed as a representation or warranty as to the efficacy or quality of any product, nor the appropriateness of any product to treat any specific condition. Physicians may direct questions about the availability and use of the products described in these materials to their authorized Acumed distributor. Specific questions patients may have about the use of the products described in these materials or the appropriateness for their own conditions should be directed to their own physician.

***These instructions have been validated for the listed devices as CAPABLE of being prepared for reuse. It is the responsibility of the healthcare facility to ensure the reprocessing as actually performed using equipment, materials and personnel in the reprocessing facility achieve the desired result. This normally requires validation and routine monitoring of the processes.***

	Part Number		Caution, consult instructions for use.		Manufacturer
	Lot Number		Do not re-use	 MR Conditional	MR Conditional. Items may safely enter the MRI Scanner environment under the specific conditions presented in the IFU
	Non-Sterile		Do not use if package is damaged	Rx Only	Caution: U.S. federal law restricts this device to sale by or on the order of a physician.
	Consult the electronic instructions for use (eIFU) at <a href="http://www.acumed.net/ifu">www.acumed.net/ifu</a>		Authorized representative in the European Community / European Union	CE	CE marking of conformity, Article 17 of EU Directive 93/42/EEC. CE marking may be accompanied by the identification number of the notified body responsible for conformity assessment
<b>Patents:</b> US – 7,635,365; 7,695,501; 8,632,573; 9,775,657 UK – GB2423935; GB2435429 JP – JP 4808621; JP 5314074 EU – EP 1667590 Other patents pending					The reticle is a registered trademark of Acumed. It may appear alone or with the Acumed name.

**CAUTION: Federal Law (USA) restricts this product sale by or on the order of a physician or hospital.**